



WARNING:

Before beginning, read these instructions in their entirety to determine if this kit is right for you. Failure to comply with these instructions could result in serious or fatal injury. Retain these instructions for future reference.

Boat ramps have certain hazards associated with their use.

- Never stand behind a watercraft while it is on the ramp.
- Never allow anyone in or on the watercraft while it is on the ramp.
- Never allow anyone to operate the ramp unless they are familiar with all of the warnings in these instructions.
- Never try to stop a free wheeling winch handle. (Always keep a firm grip on the handle while the ratchet pawl is not engaged.)
- Never allow watercraft to roll free down the ramp. Injury may occur or damage to watercraft or ramp may occur.

Hardware:

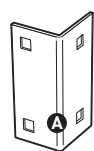

Inside Corners
6 x



Washer Plates
18 x

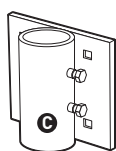

Leg Holders
2 x

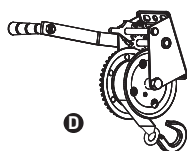

Winch
1 x

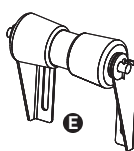

Keel Roller
1 x

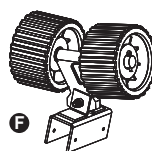

Wheels
8 x

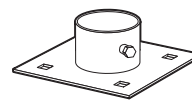

Base Plates
2 x



Leg Caps
2 x

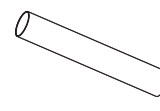

Leg Pipes
2 x

Tools Required:

- Saw/Mitre saw
- Level
- Tape measure
- Robertson bit screwdriver
- Screwdriver
- 7/16" Wrench
- 3/4" Wrench
- Drill
- Hammer
- Pen or pencil

Lumber Required:	Qty.
2" x 8" x 16'	2
2" x 6" x 8'	2
2" x 4" x 10'	1

Fasteners Included:

	Qty.	Size	Length
For Hardware: Carriage Bolts with Nuts and Lock Washers	36	3/8"	2-1/2"
For Winch: Carriage Bolts with Nuts, Lock and Flat Washers	3	3/8"	4-1/2"
Stainless Steel Truss Head Screws	6	#8	1"
Wood Screws for Frame Assembly	50	#10	3"
Wood Screws for Wheel Assembly	40	#10	1/2"

Parts Required:

	Qty.	Size	Length
Side Beams	2	2" x 8"	192" (16')
End Beam (for leg holders)	1	2" x 6"	72" (6') ¹
Cross Struts	5 or 6	2" x 6"	21" ¹
Winch Post	2	2" x 4"	29" ²
Winch Post Brace	1	2" x 4"	23"
Post Brace Enforcement	2	2" x 4"	6"

¹ End Beam and Cross Strut length may vary depending on your boat width or type.

² Winch Post may also be one - 4" x 4" .

It is recommended that 2 persons assemble and install the mooring ramp. Estimated time of assembly is 3-4 hours. Before assembly can begin, you will need to take certain measurements of your boat based on its characteristics and adjust the layout based on your situation.

It is recommended that 2 persons assemble and install the mooring ramp. Estimated time of assembly is 3-4 hours. Before assembly can begin, you will need to take certain measurements of your boat based on its characteristics and adjust the layout based on your situation.

1 To determine the ramp width, take a measurement of the location of the ideal position of the wheels under the hull. This will be your cross struts dimension. Remember for "V" shaped hulls, the greater the distance between the wheels, the lower the boat will be.

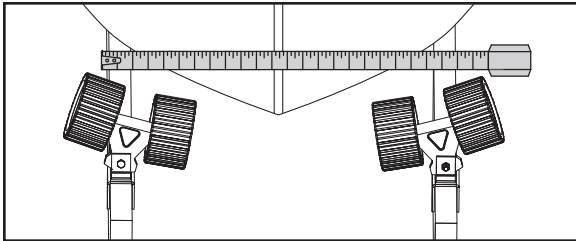

2 To make sure your pipes are straight, position the end of a 2" x 8" beam on the shore where the ramp will be installed. Position the other end of the beam 2 inches under the water surface. Using a long level maintained straight, mark a cutting line. Mark the other end of the 2" x 8" at 25° for the winch installation. Transfer these marks to the other beam and cut both beams.

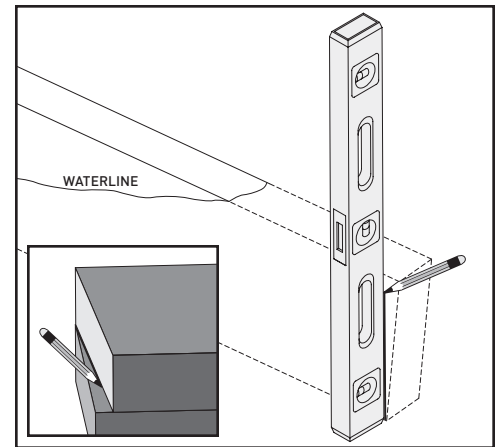

3 Cut the 2" x 8" ends above the keel roller at 45° as shown.

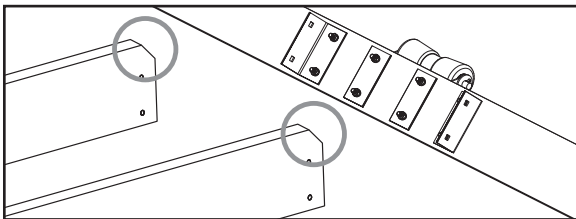

4 Assemble the structure with screws as in image at bottom of this page. Take care not to insert screws where bolts will be located.

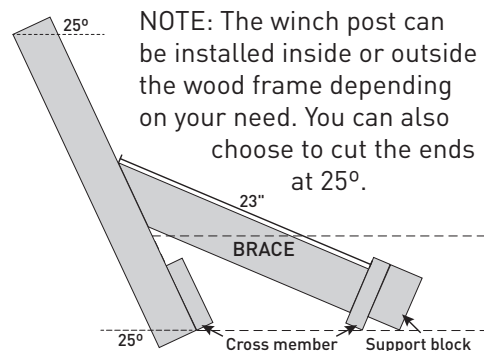
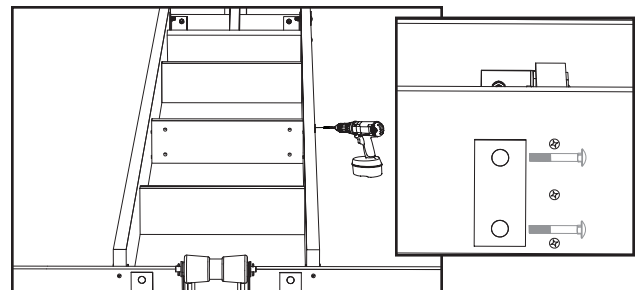

5 The winch post should be a 4" x 4" or combine two lengths of 2" x 4". Assemble the brace with the cross beam (may be done separately) and connect to the structure and winch post. Add 2" x 4" or 2" x 6" support blocks at the rear of the winch's cross strut and fasten with screws.

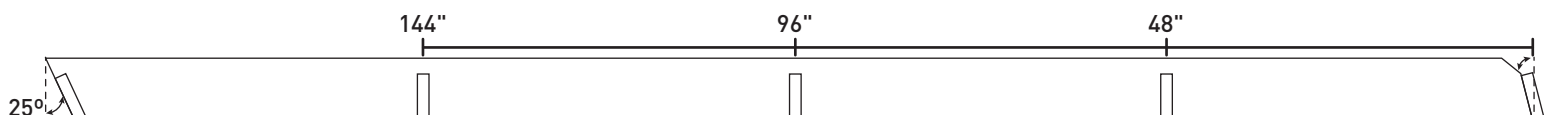
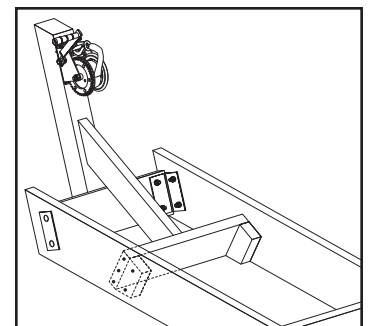

1 Note the hardware locations according to image at bottom of this page.

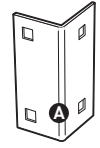

Inside Corners
6 x



Washer Plates
18 x

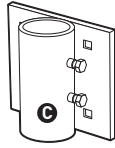

Leg Holders
2 x

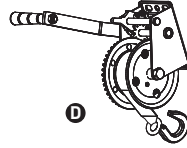

Winch
1 x

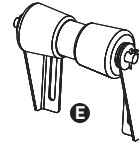

Keel Roller
1 x

You can install the hardware once the entire structure is assembled with screws or pre-assemble some sections that you will connect later.

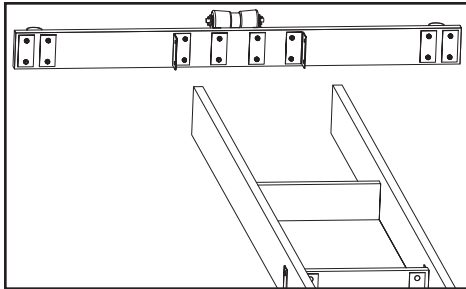

2 Position the hardware parts and mark the holes with a pen or pencil.

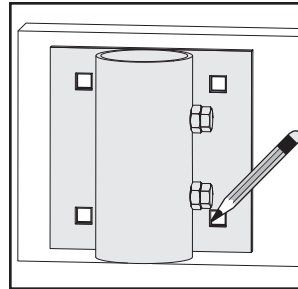

3 Drill out marked holes with the 7/16" drill bit.

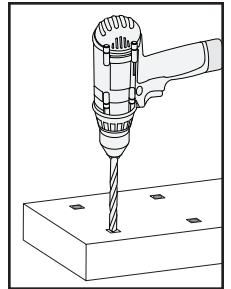

4 Install the hardware components with the 3/8" x 2-1/2" bolt, nut & lock washer combination.

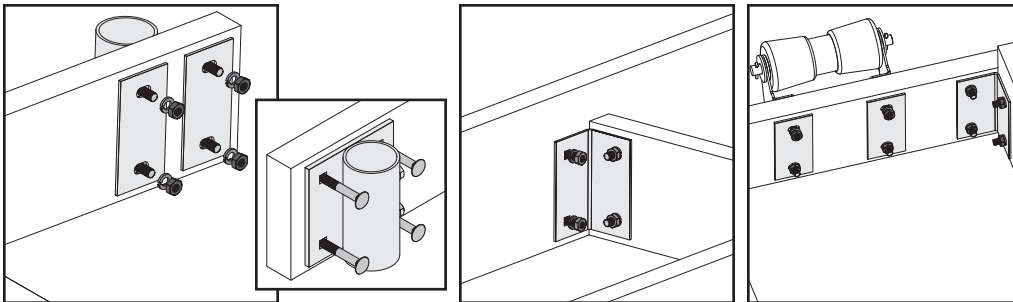

5 Install the Winch using the 3/8" x 4-1/2" bolt, nut, lock & flat washer combination.

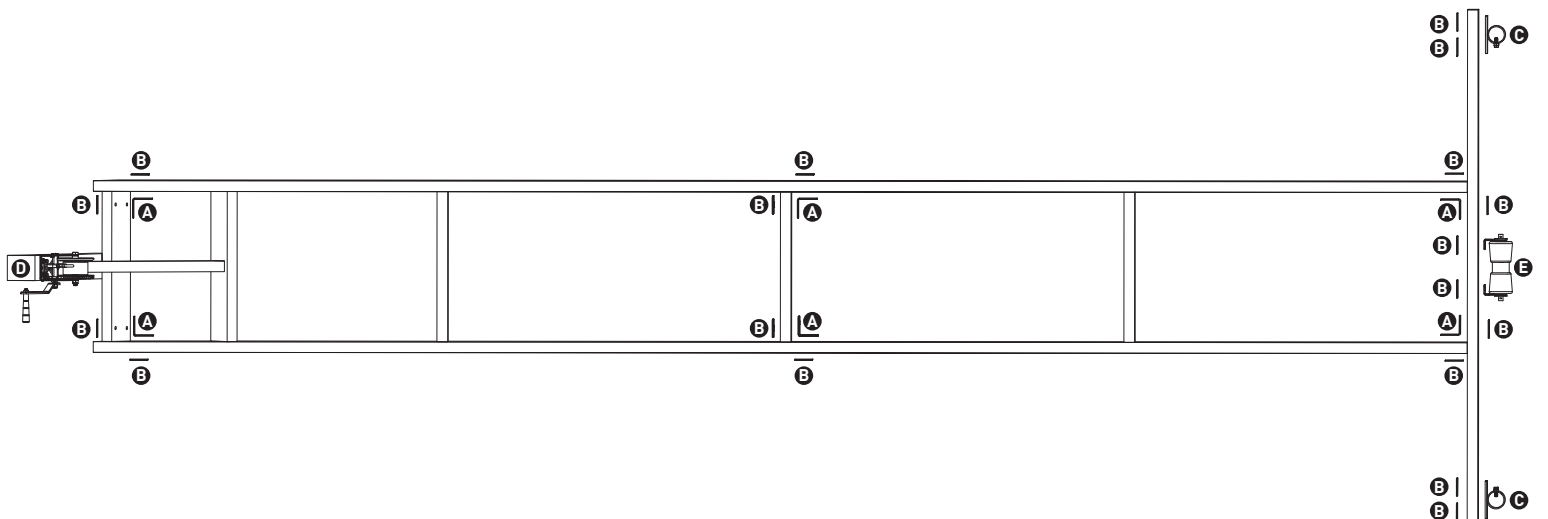
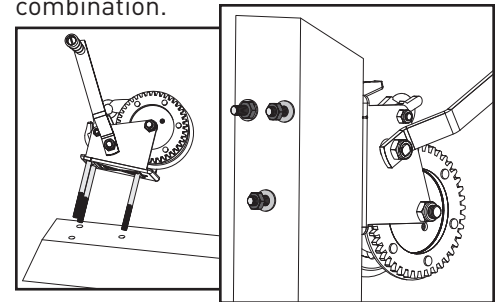

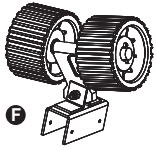

Wheels
8 x

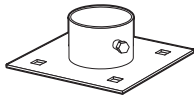

Base Plates
2 x



Leg Caps
2 x

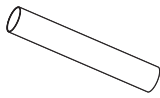

Leg Pipes
2 x

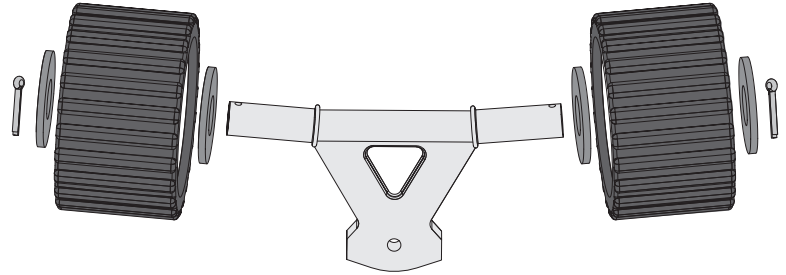

1 Assemble the wheels as shown above with the flat washers and the pins.

2 Add the base to the wheel assembly. Position the axle on the base so that there is a lean to the center of the ramp. Note that the bottom of the axle "T" has a curved edge which serves to hinder the rocking movement thereby keeping the wheels leaning towards the center of the ramp.

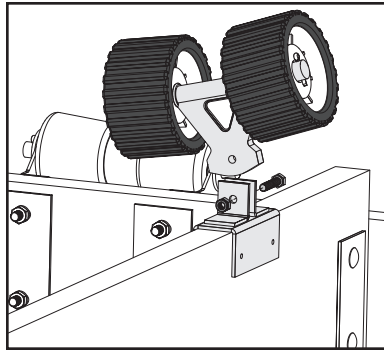

3 Position the wheels according to the distances proposed in the image at bottom of this page. A ramp with 3 pairs of wheels will support a 2000 lb. boat, while 4 pairs of wheels will guide up to 2500 lbs.

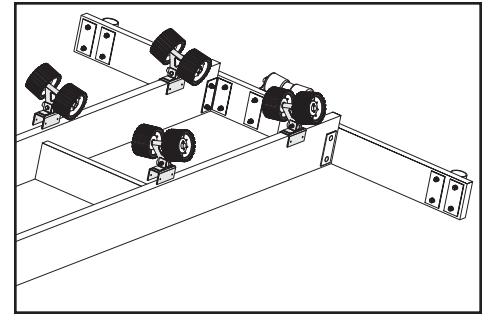

4 Screw the wheel bases to the structure.

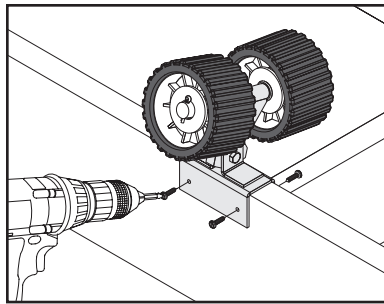

5 Slide the pipes into the leg holders and tighten temporarily with one of the leg holder hex bolts. Install the base plates roughly 6" from the ends of the pipes.

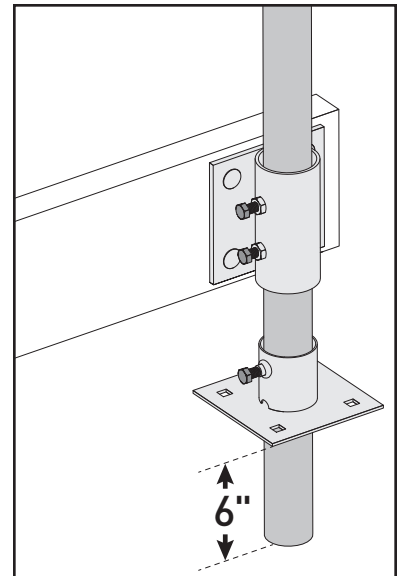

6 Move the ramp to its intended location. If the ramp floats, hammer the Leg Pipes deeper into the ground for a better footing. Once the ramp is in position, place the leg caps on the leg pipes.

7 Depending on the quality of the bed where the ramp will rest, you may need to use larger base plates or to add planks in the water under the base plates to prevent the pipes from sinking.

8 Remove the ramp from the water during winter to prevent ice damage.

